

CNC-AF/DF-PV40+(R)TP(V)40 DRAW/REDRAW LINE & TRIMMING



- Material**
- Aluminum
 - Tinplate
 - DR-TFS
- Capacity**
- up to 520 cans/min.

- Tooling**
- 2-, 3- and 4-out
 - tool steel or carbide
- Changeover Time**
- < 3 hours incl. tool change

- Hydraulic overload safety device
- Playfree preloaded antifriction roller guidance
- Crankshaft on roller bearings

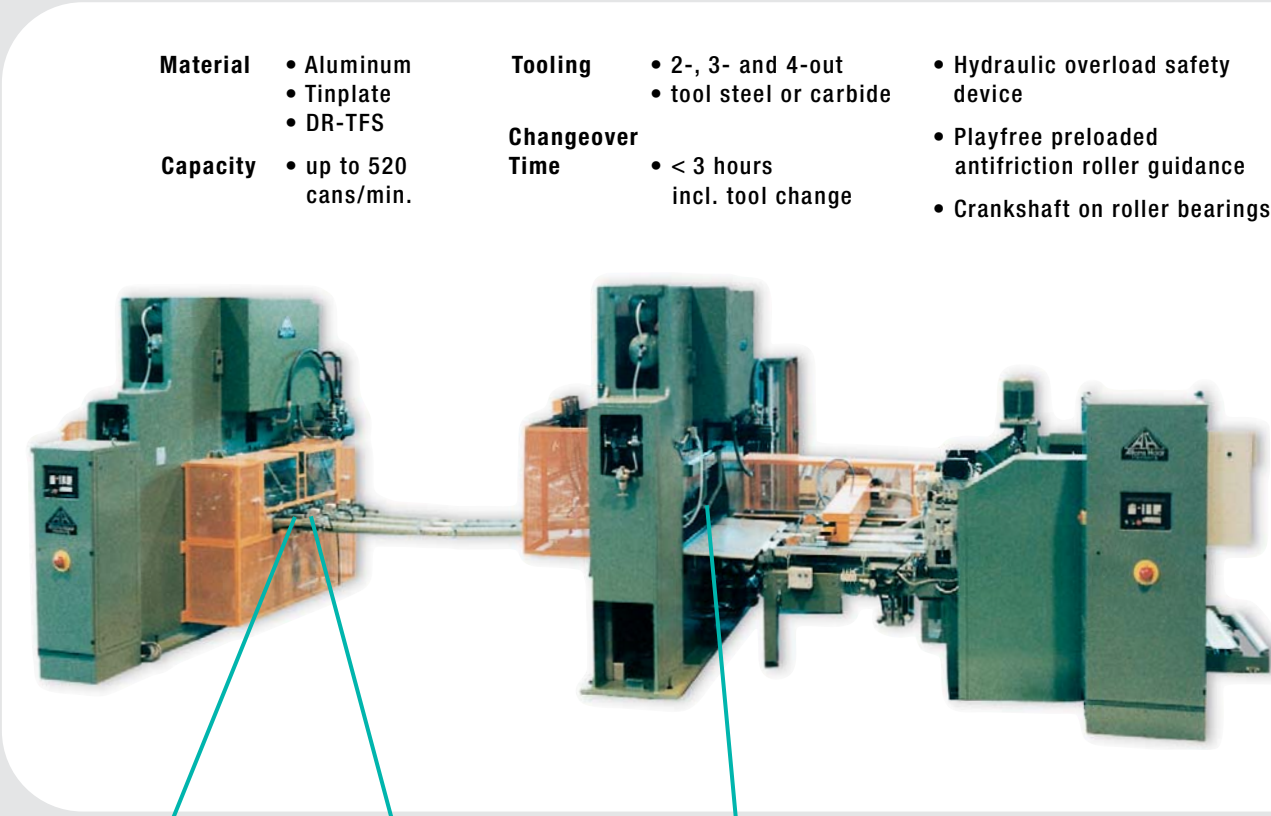

CNC-AF/DF-PV40+(R)TP(V)40 DRAW/REDRAW LINE & TRIMMING

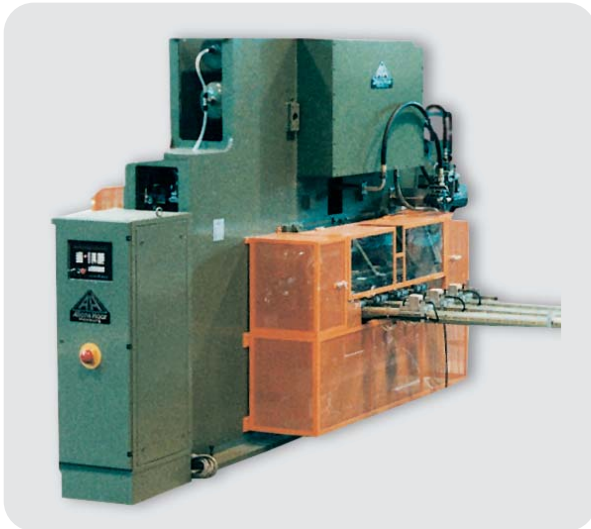

TECHNICAL DATA

TYPE:	RTPV 40
CAPACITY:	40 t
STROKE LENGTH:	170 mm
SPEED MAX:	60-130 rpm
TOOLING:	1-4-out
DRIVING POWER:	18,5 kW
DRIVE:	GEARING
CAN DIAMETER:	100 mm 3.937 inch
CAN HEIGHT:	45 mm; 1.772 inch
SHEET SIZE:	1150 x 1000 mm 45 x 39 inch

