

PBVL / PBVM / PBVO

Pneumatic Bottom Valves



Alfons Haar

ADR2005 certified according to: TÜ.AGG.235-95

Non-pressure compensated acc. to EN 13308

Pressure compensated acc. to EN 13316

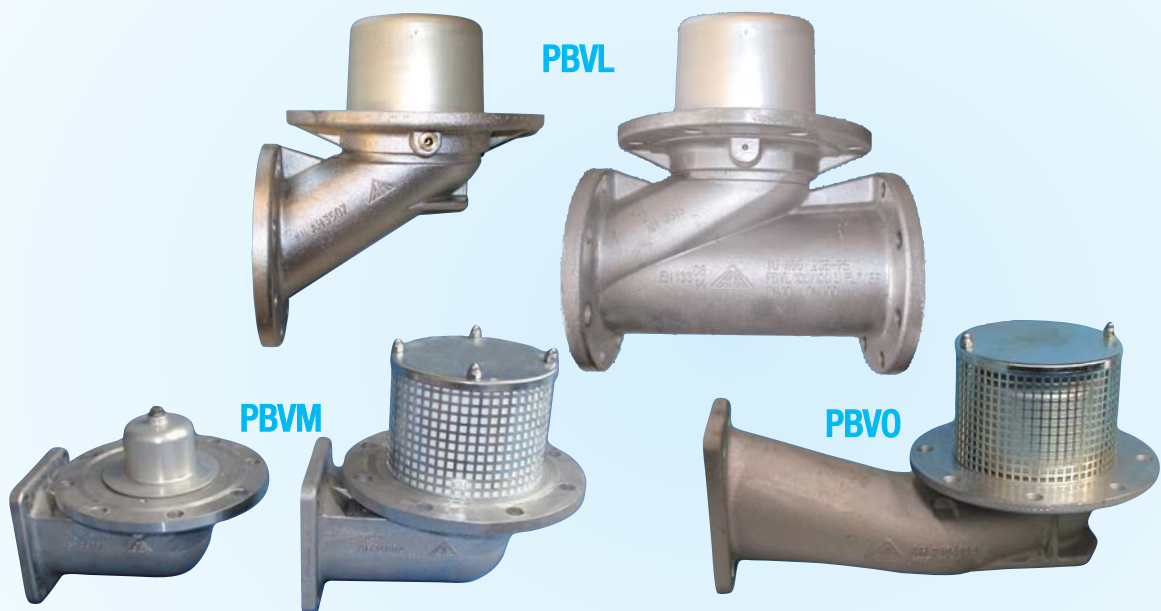

Pressure balanced version usable as shut off valve for bottom loading and also for overfill prevention

(Hydraulic opening pressure: 13.6 to 15.5 bar)

Complete safe separation of product and compressed air:
no fuel in the compressed air at any time

All bottom valves:

- Nominal pressure 10 bar
- Extremely low pressure loss for maximum delivery rate with vortex breaker
- Complete separation of product and compressed air
- attenuation to avoid pressure peaks
- pre-determined breaking points to protect the tank compartment
- TÜV certified, component label: TÜ.AGG.235-95
- Working temperature range regular operation: -20° to +50 °C
- Low-maintenance and fail-safe
 - Coated surface
 - VITON sealings
- Low weight
- Easy exchange of the main gasket

PBVL / PBVM / PBVO

Pneumatic Bottom Valves



Alfons Haar

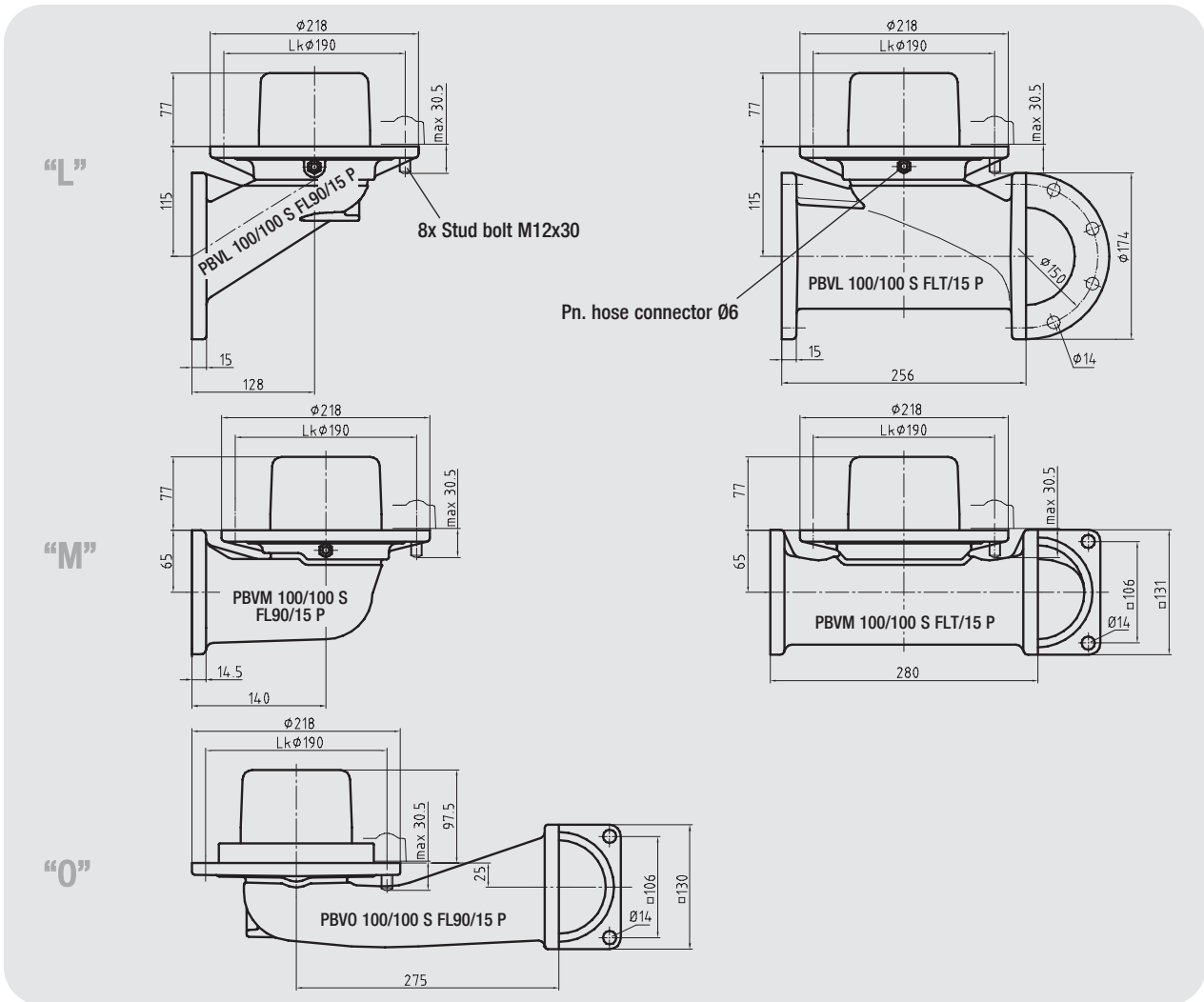

Pressure balanced acc. to EN 13316

90° Design

T Design

"L" with TW 3 flanges	2132646	PBVL 100/100 S FL90/15P	2161689	PBVL 100/100 S FLT/15P
"M" with square fl. short design	2146275	PBVM 100/100 S FL90/15P	2162515	PBVM 100/100 S FLT/15P
"O" with square fl. long design	2165434	PBVO 100/100 S FL90/15P		

Non pressure balanced acc. to EN 13308

90° Design

T Design

"L" with TW 3 flanges	2166414	PBVL 100/100 U FL90 P	2161815	PBVL 100/100 U FLT P
"M" with square fl. short design	2157083	PBVM 100/100 U FL90 P	2162466	PBVM 100/100 U FLT P
"O" with square fl. long design	2165245	PBVO 100/100 U FL90 P		

Accessories

1001759	Weld-in flange AL (tank)	1141690	TW 3 weld-on flange
1037036	Flange gasket (tank)	1068667	TW 3 gasket
1147567	Weld-on flange square	2144924	Strainer basket complete