

# TruckFIT 800

Vane Pump with  
Integral Multi-Way Valve

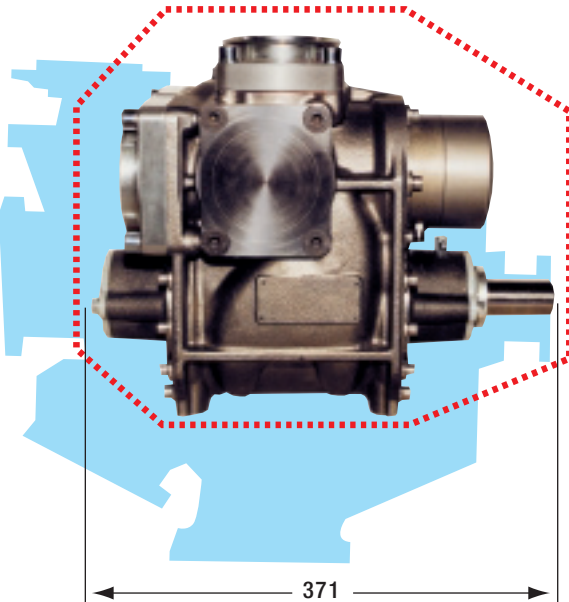

**Alfons Haar**



## Smooth performance!

40-years of experience and computer aided hydrodynamic flow makes the vane pump whisper.

The high efficiency of the TruckFIT 800 reduces fuel consumption and engine emissions by up to 50%.

Full hose delivery at idle speed.

## Fits any truck chassis frame!

### VANE PUMP

- Compact design
- Blow-down for product change
- Self-priming

Multi-way valve pneumatically operated, continuous flow control via by-pass valve.

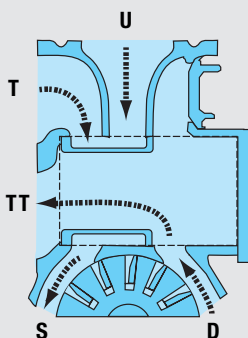
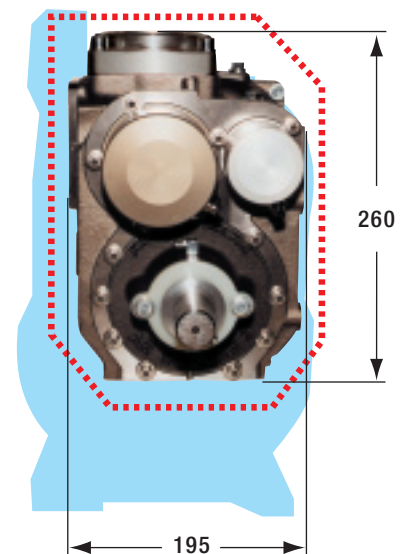

**SELF-LOADING**  
From trailer or external tank

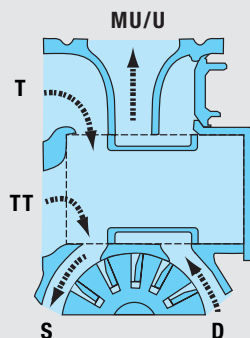

**PUMPED DELIVERY**  
From tank or trailer

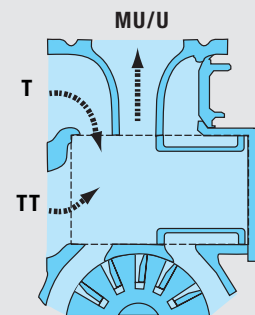

**GRAVITY DISCHARGE**  
From tank or trailer

# TruckFIT 800

## Vane Pump with Integral Multi-Way Valve

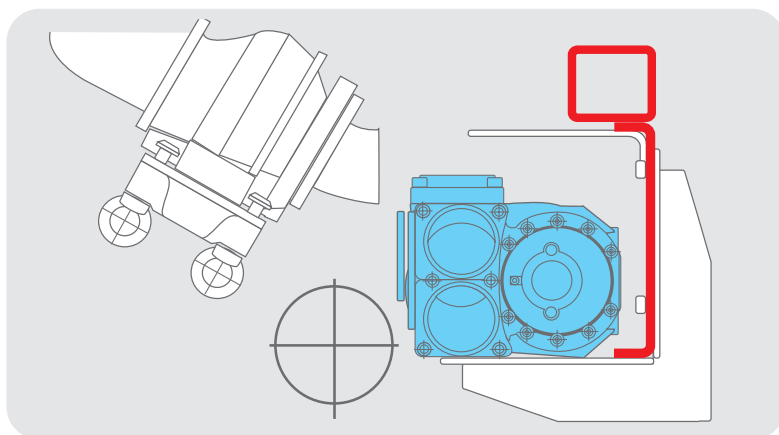
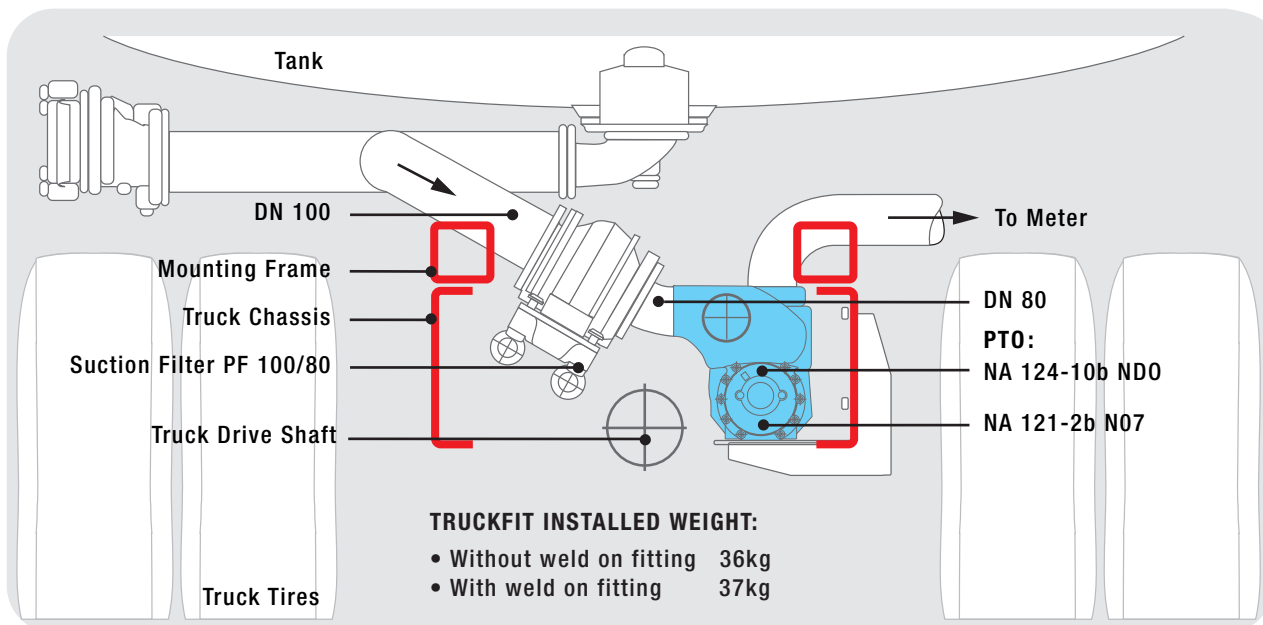

### TRUCKFIT PERFORMANCE DIAGRAM

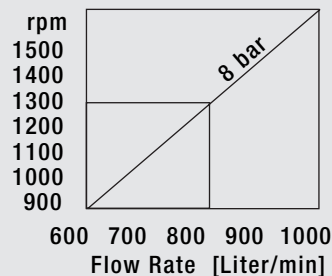

### PRECIMA 500 + 800 TO OPERATE WITH MEASURING UNITS: PRECIMA 500 + 800

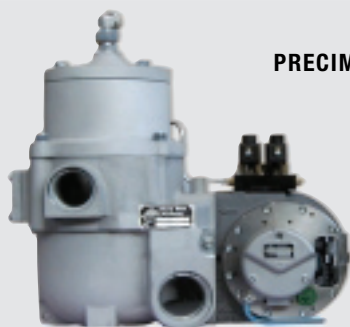

**PRECIMA 500**

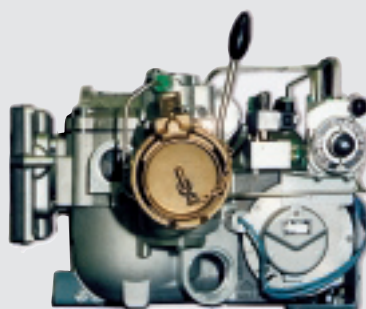

**PRECIMA 800**

- 800 l/min
- Wet hose
- and dry hose