

# CNC-CF/DF-P40S COIL/SHEET FEED PRESS

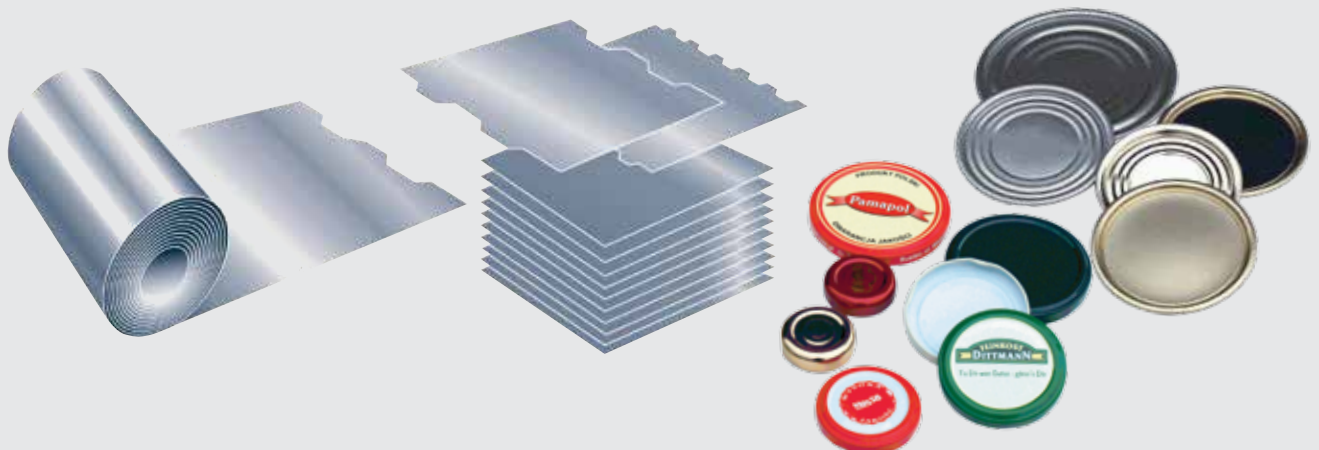

- Highly flexible press center
- 100% automation
- Material savings by utmost precision feed
- Manpower savings by direct sheet processing, eliminating strip shearing
- Flexibility by shortest changeover times
- Hydraulic overload safety device
- Crankshaft roller bearings
- Preloaded, playfree roller ram guidance
- AC-maindrive with static frequency converter including recuperation of flywheel brake energy
- Main motor driven slowmotion for the ram
- Die alignment system with electronic control

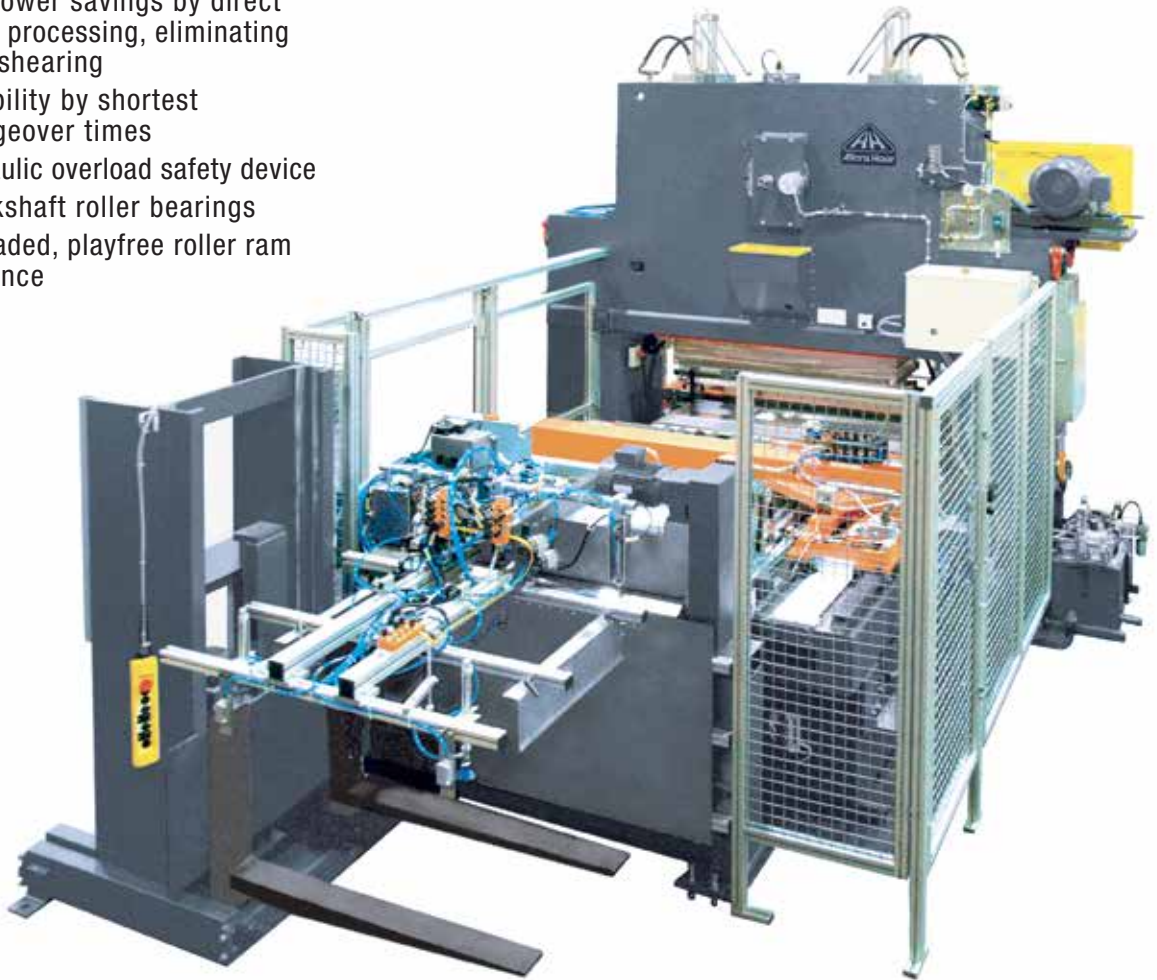

# CNC-CF/DF-P40S COIL/SHEET FEED PRESS



## TECHNICAL DATA

CAPACITY	40t optional 50t
STROKE LENGTH	120 mm
SPEED MAX	250 spm
TOOLING	max. 16-out
DRIVING POWER	15 kW
DRIVE	DIRECT
CUT EDGE DIAMETER	250
DRAW DEPTH	25 mm/9,8425 inch
SHEET SIZE	1,150 x 1,000 mm 45 x 39 inch
COIL WIDTH	1200 mm

## MATERIAL

- Scrolled and unscrolled sheets  
0,1-0,5mm /.004"-.02"
- Coil
- Aluminum
- Tinplate
- DR-TFS

## OUTPUT

- Ends/Shells up to 4000epm

## CHANGEOVER TIME

- < 1 hour incl. tool change



16 roller rotary elements  
hydraulic overload safety  
device with combined ram  
adjustment

Reliable & Service friendly by uncompromising use of up-to-date-components in modular design.

DF

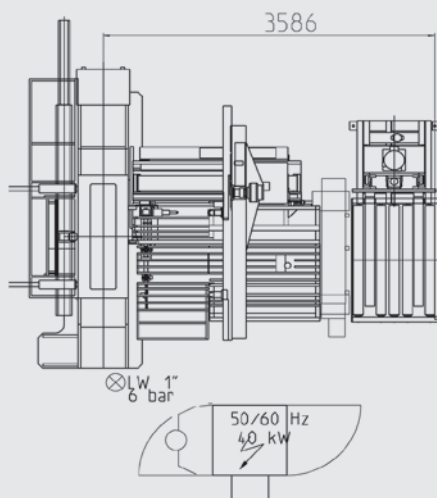

CF

