

CNC-AF/DF-PV40+DRMTPV 50 DRAW/REDRAW LINE & TRIMMING



- Material**
- Aluminum
 - Tinplate
 - DR-TFS
- Capacity**
- up to 520 cans/min.

- Tooling**
- 2-, 3- and 4-out
 - tool steel or carbide
- Changeover Time**
- < 3 hours incl. tool change

- Hydraulic overload safety device
- Playfree preloaded antifriction roller guidance
- Crankshaft on roller bearings

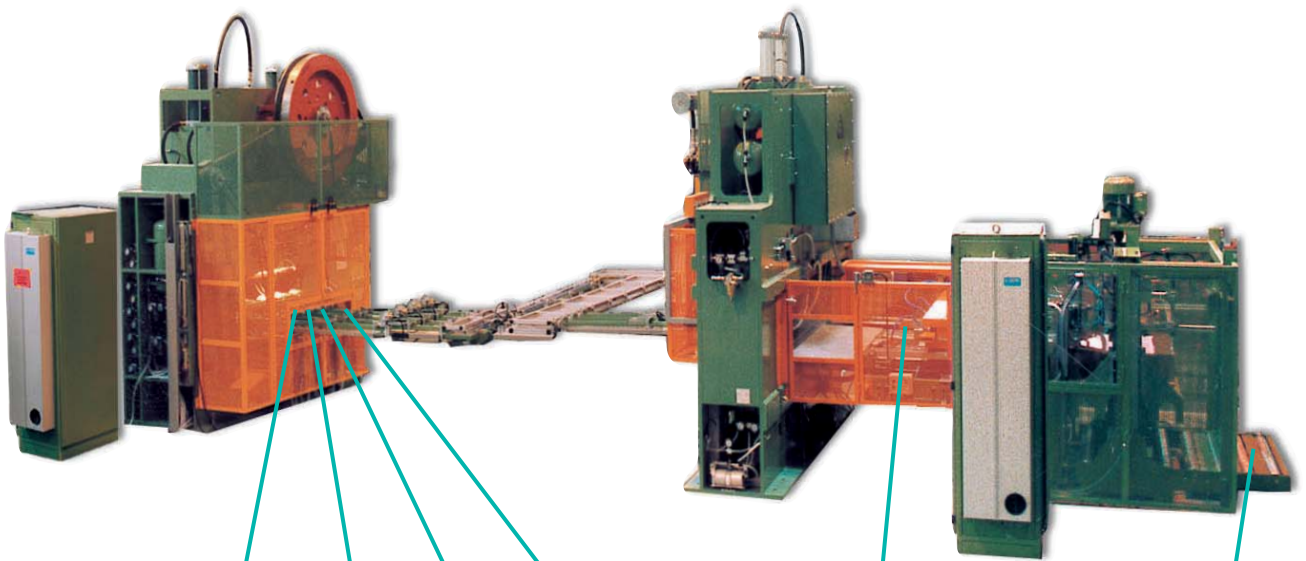

TRIMMING ◀ PANELLING ◀ REDRAW ◀ REDRAW ◀ CUPPING ◀ SHEET

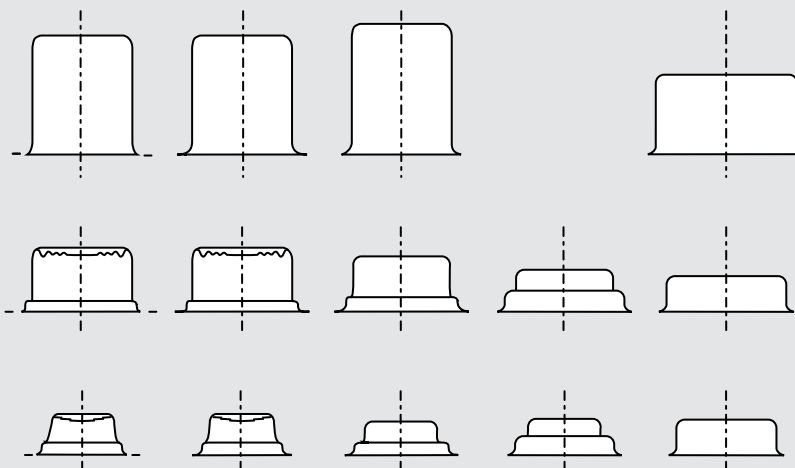

CNC - AF/DF - PV40+DRMTPV 50 DRAW/REDRAW LINE & TRIMMING



TECHNICAL DATA

TYPE:	DRMTPV 50
CAPACITY:	50 t
STROKE LENGTH:	200 - 280 mm
SPEED MAX:	70-130 rpm
DRIVING POWER:	30 kW
DRIVE:	GEARING
TOOLING:	up to 4-out
CAN DIAMETER:	100 mm 3.937 inch
CAN HEIGHT:	86 mm; 3.386 inch

