

CNC-DF/AF-P35 (d) SHEET FEED PRESS



- Highly flexible press center
 - 100% automation
 - Material savings by utmost precision feed
 - Manpower savings by direct sheet processing eliminating strip shearing
 - Flexibility by shortest changeover times
 - Hydraulic overload safety device
 - Preloaded, playfree roller ram guidance
 - AC-maindrive with static frequency converter
 - Electrical flywheel brake
 - Main motor driven slow motion for the ram
 - Die alignment system with electronic control
- Optional:
Quick die change system



Multi die



Double die



CNC-DF/AF-P35(d) SHEET FEED PRESS



TECHNICAL DATA

TYPE:	P	Pd
CAPACITY:	35 t	35 t
STROKE LENGTH:	120 mm	120 mm
SPEED MAX:	260 rpm	200 rpm
DIES:	2-8	2-8
POWER:	7,5 kW	15 kW
BLANK DIAMETER:	200 mm	200 mm
DRAW DEPTH:	25 mm; 0.984 inch	40 mm; 1.575 inch
SHEET SIZE MAX:	1150 x 1000 mm 45 x 39 inch	1150 x 1000 mm 45 x 39 inch



Lightweight ram

Material

- Scrolled and unscrolled sheets 0,1 - 0,5 mm / .004" - .02"
- Aluminum
- Tinplate
- DR-TFS

Output

- Cans up to 520 cpm (4-out)
- Ends up to 1800 cpm (8-out)

Quick Change

- < 1 hour incl. tool change

Reliable & Service friendly
by uncompromising use of
up-to-date-components in
modular construction.

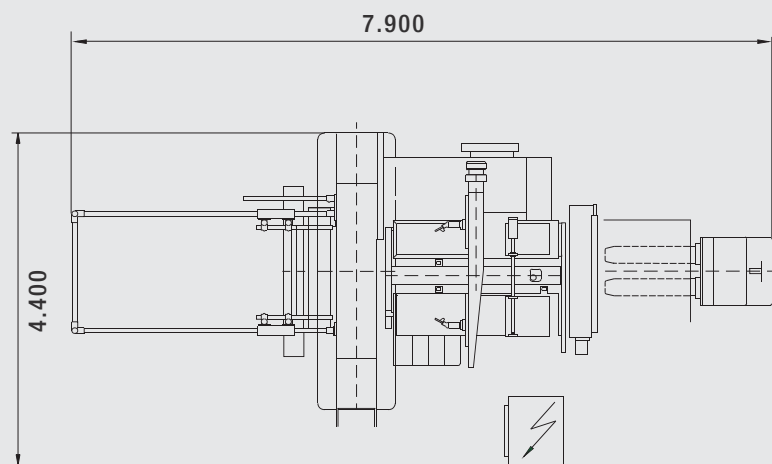

20 kW

AIR SUPPLY: 6 bar
HEIGHT: 3,1 m

TYPE DF with Linear Motor Technology



TYPE AF

