

FPO 80

TANK TRUCK VANE PUMP



SELF-PRIMING VANE PUMP

Depending on selected pump size up to 1230 l/min with $\Delta p = 10$ bar

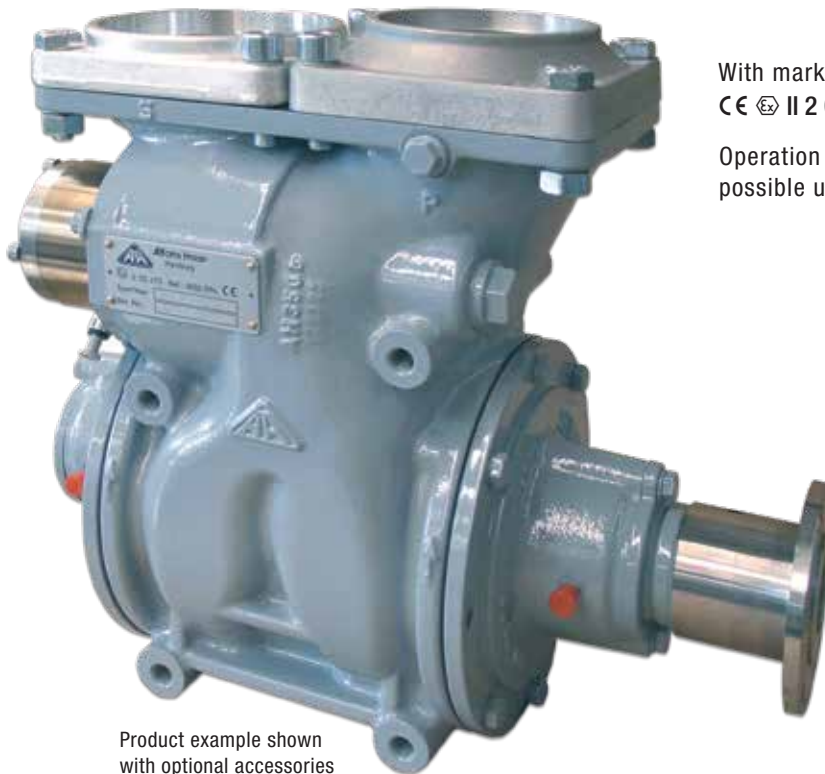

Product example shown
with optional accessories

With marking
CE  II 2 G Ex h IIA T4 ... T2 Gb X

Operation without flame arrester
possible under ATEX conditions

FUNCTIONS

- Computer optimized 4" to 3" suction cross section for a quiet pump operation and high discharge rate.
- Large integrated pneumatic or mechanical by-pass valve.
- Ideal 4" and 3" block flange for connection of the pipework to tank truck pump
- Very good blow down for product change
- Excellent working life and simple service
- PTO or hydraulic drive
- Housing material: Grey cast iron
Shaft / Rotor: Steel
Vaness: POM compound – reinforced by steel inlay
- No copper alloys, copper plating or galvanised steel – JIG compliant!

FPO 80

TANK TRUCK VANE PUMP



DIMENSIONS

FPO... 80-700
-900

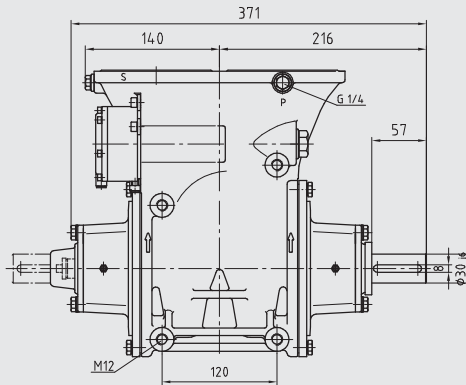

FPO G 80 -

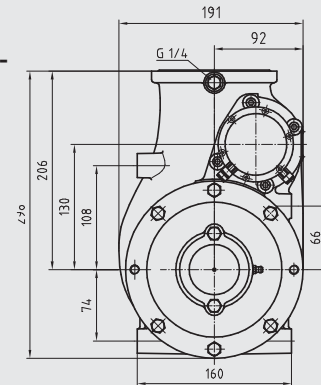

FPO S 80 -

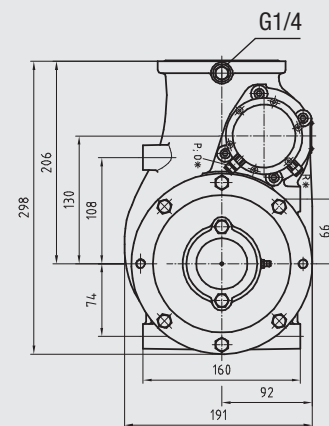
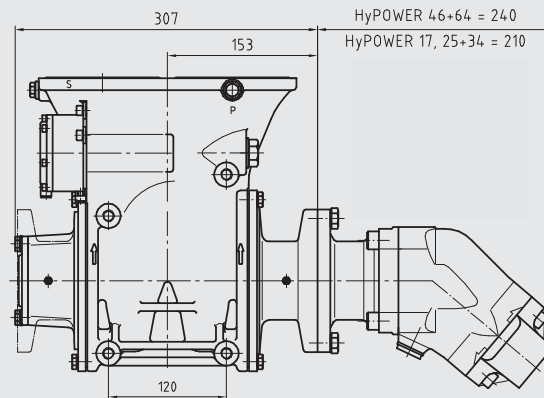

FLOW RATE at $\Delta p = 10$ bar

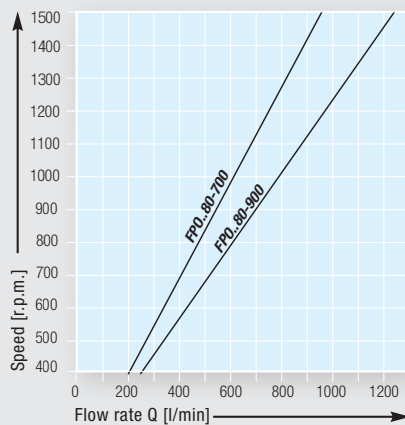

INPUT POWER at $\Delta p = 10$ bar

The input powers of the pump are minimum values for non-viscous media with viscosities up to approx. 12 cSt as e.g. heating oil EL, diesel and motor gasoline.

