

PreciMA C490

PreciCONTROL BASED MEASURING UNIT



SAVE COSTS SAVE SPACE + WEIGHT

- 490 l/min wet hose 2"
- Dry ventilation without wet return pipe

MID + ATEX approved



CountMASTER 4A
Interactive interface
between user and
measuring unit

- Total safety against unintended measurement of air
- Completely mounted and configured ex works, ready to be installed and easily connected
- Full automatic control of all loading and discharge functions
- Long-term reliability of electronics due to robust, burn-in tested potting technology
- Contamination on product change limited to only 0.7 liters of residual volume inside PreciMA
- Easy electrical installation uses Field bus wiring system "PreciBUS". No wiring looms or terminal boxes
- Pneumatic logic elements and control blocks are no longer necessary

- ✓ Compact design -
Up to 85% smaller than
conventional metering systems
More space e.g. for additive tanks
per year = 396 €
- ✓ Up to 80% less system weight
Increased payload savings
per year = 535 €
- ✓ Up to 1000 € savings
on installation with simple fitting
connections
4 hours labour saved!

PreciMA C490

PreciCONTROL BASED MEASURING UNIT



COMPONENTS

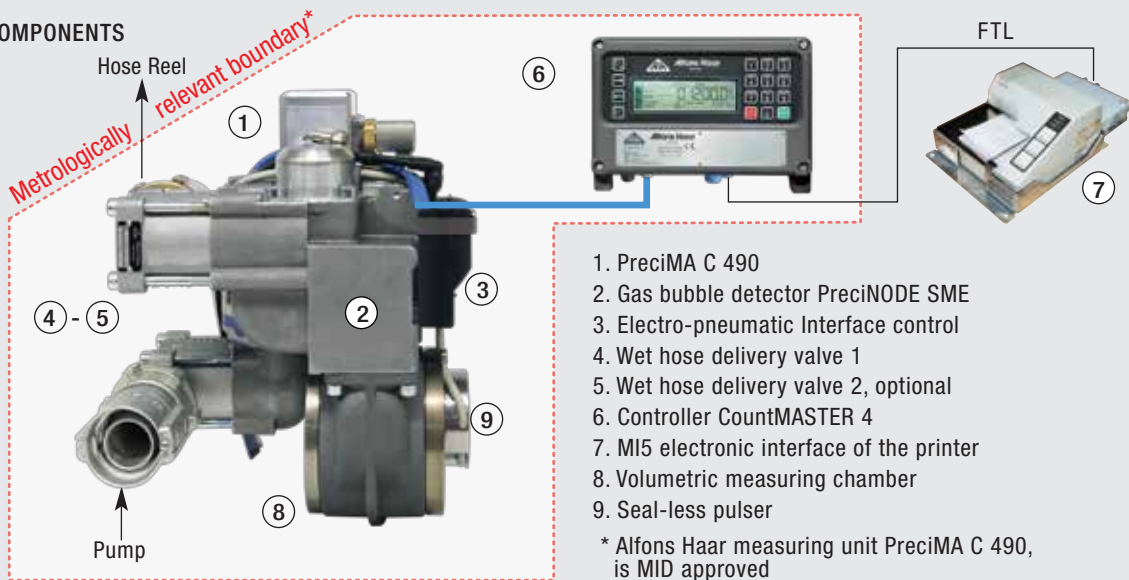

1. PreciMA C 490
 2. Gas bubble detector PreciNODE SME
 3. Electro-pneumatic Interface control
 4. Wet hose delivery valve 1
 5. Wet hose delivery valve 2, optional
 6. Controller CountMASTER 4
 7. MI5 electronic interface of the printer
 8. Volumetric measuring chamber
 9. Seal-less pulser
- * Alfons Haar measuring unit PreciMA C 490, is MID approved

DIMENSIONS

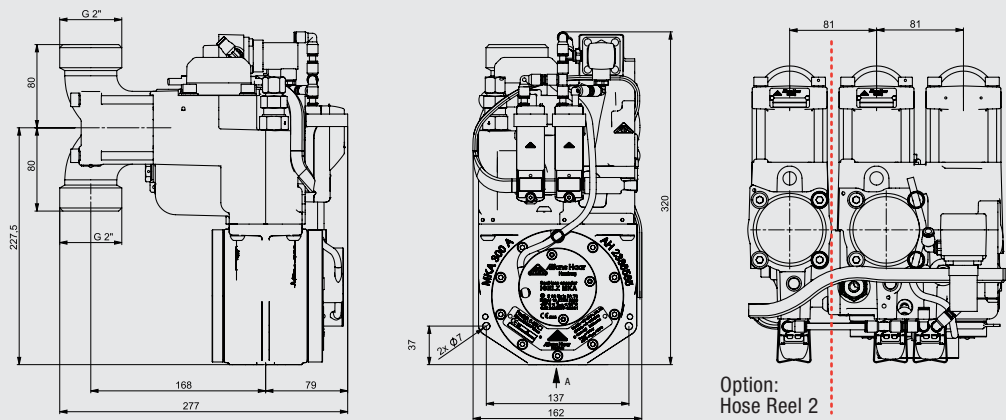

TECHNICAL DATA

WEIGHT:	14,5 - 17,7 kg
MEASUREMENT RANGE:	50 l/min - 500 l/min
MINIMUM MEASURING QUANTITY:	50 liters
MEASURING PRODUCT:	Liquids, except water, with a kinematic viscosity of <20mPas at 20°C, e.g. diesel, kerosene, heating oil, bio diesel.
MAX. OPERATION PRESSURE:	10 bar
POWER SUPPLY:	24V V DC on-board electronic unit (15....32V)

OPTIONS

The central controller, CountMASTER 4, can be extended by software upgrade:

- Product Return with Flow Check
- Wet hose delivery valve 2

(For more information see separate brochures)